

# V-band Self-heterodyne Wireless Transceiver using MMIC Modules

Dan An, Mun-Kyo Lee, Sang-Jin Lee, Du-Hyun Ko, Jin-Man Jin, Sung-Chan Kim,  
Sam-Dong Kim, Hyun-Chang Park, Hyung-Moo Park, and Jin-Koo Rhee

**Abstract**—We report on a low-cost V-band wireless transceiver with no use of any local oscillator in the receiver block using a self-heterodyne architecture. V-band millimeter-wave monolithic IC (MMIC) modules were developed to demonstrate the wireless transceiver using coplanar waveguide (CPW) and GaAs PHEMT technologies. The MMIC modules such as the MMIC low noise amplifier (LNA), medium power amplifier (MPA) and the up/down-mixer were installed in the transceiver system. To interface the MMIC chips with the component modules for the transceiver system, CPW-to-waveguide fin-line transition modules of WR-15 type were designed and fabricated. The fabricated LNA modules showed a  $S_{21}$  gain of 8.4 dB and a noise figure of 5.6 dB at 58 GHz. The MPA modules exhibited a gain of 6.9 dB and a  $P_{1\text{ dB}}$  of 5.4 dBm at 58 GHz. The conversion losses of the up-mixer and the down-mixer module were 14.3 dB at a LO power of 15 dBm, and 19.7 dB at a LO power of 0 dBm, respectively. From the measurement of V-band wireless transceiver, a conversion gain of 0.2 dB and a  $P_{1\text{ dB}}$  of 5.2 dBm were obtained in the transmitter block. The receiver block showed a conversion gain of 2.1 dB and a  $P_{1\text{ dB}}$  of -18.6 dBm. The wireless transceiver system demonstrated a successful data transfer within a distance of 5 meters.

**Index Terms**—MMIC, self-heterodyne, wireless transceiver, V-band, module

## I. INTRODUCTION

The system cost of millimeter-wave wireless transceiver system becomes very high mainly due to the use of local oscillator (LO). A double-side band (DSB) self-heterodyne communication method can reduce the number of necessary local oscillators required for the system because the LO signals are used only in the transmitter part, but not in the receiver part. For this reason, for a short-range wireless communication, the DSB self-heterodyne system with no filter and local oscillator in the receiver block can be a cost-effective [1]. To realize wireless communication systems with a commercially competitive edge, the availability of compact and low-cost monolithic millimeter-wave integrated circuit (MMIC) modules are also essential.

In this paper, we present a low-cost MMIC-based V-band wireless transceiver system using the DSB self-heterodyne communication structure. The V-band MMIC modules were developed to demonstrate operation of the V-band wireless transceiver by using the MMIC technology of 0.1  $\mu\text{m}$  GaAs pseudomorphic high electron mobility transistors (PHEMTs) and coplanar waveguide (CPW) transmission lines. Moreover, the module components were assembled and optimized for the whole transceiver system, and the system performance and its characteristics were analyzed.

## II. DEVELOPMENT OF MMIC LIBRARIES

GaAs PHEMTs of a 0.1  $\mu\text{m}$  gate length have been

developed for the active components of V-band MMIC low noise amplifier (LNA), medium power amplifier (MPA) and down-mixer modules. A double delta-doped heterojunction epitaxial structure with a pseudomorphic  $\text{In}_{0.2}\text{Ga}_{0.8}\text{As}$  channel was used to achieve high performance PHEMTs. The epitaxial structure used for the PHEMTs was grown as followings. Atop a 5000 Å undoped GaAs buffer and a 2000 Å of super lattice, a bottom delta doping ( $1 \times 10^{12} \text{ cm}^{-2}$ ), a 60 Å undoped spacer, a 120 Å undoped  $\text{In}_{0.2}\text{Ga}_{0.8}\text{As}$  channel, a 40 Å undoped  $\text{Al}_{0.25}\text{Ga}_{0.75}\text{As}$  spacer layer, a top delta doping ( $5 \times 10^{12} \text{ cm}^{-2}$ ), a 250 Å undoped  $\text{Al}_{0.25}\text{Ga}_{0.75}\text{As}$  Schottky barrier layer and a 300 Å n-type GaAs cap ( $5 \times 10^{18} \text{ cm}^{-3}$ ) were grown sequentially [2]. For the drain/source contacts of the PHEMTs, AuGe/Ni/Au metal systems were used to achieve a low ohmic contact resistance of  $\sim 1 \times 10^{-7} \Omega \cdot \text{cm}^2$ . Prior to ohmic contact formation, mesa etching process was carried out to isolate the active regions. A 0.1 μm Γ-shaped gate was then patterned by using the triple-layer resist (PMMA/P(MMA-MAA)/PMMA) in a 50 keV electron-beam lithography system. After the gate fabrication, the  $\text{Si}_3\text{N}_4$  passivation was deposited to protect the device, and air-bridge metals of Ti/Au were then formed to interconnect the isolated electrodes. The fabricated PHEMTs showed a maximum drain current density ( $I_{d,\text{max}}$ ) of 373.5 mA/mm, a maximum extrinsic transconductance ( $g_m$ ) of 522.4 mS/mm, a maximum frequency of oscillation ( $f_{\text{max}}$ ) of 180 GHz, and a cut-off frequency ( $f_T$ ) of 113 GHz.

For a parameter extraction from the PHEMT device, a nonlinear large signal model of EEHEMT1 (EEs of scalable nonlinear HEMT model) was used [3-4], and a good agreement was obtained with the measurements over the frequency range of 1 to 50 GHz. Figure 1 shows parameter extraction procedure using the large signal model for our PHEMTs.

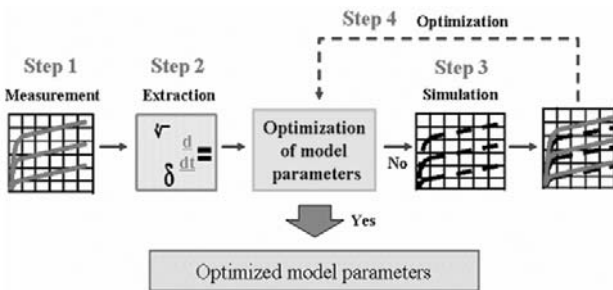

Fig. 1. The parameter extraction procedure using the large signal model.

For the transmission line structure, we used the CPWs because no backside process is necessary, and a higher fabrication yield, in general, is achievable than in microstrip structure [5-6]. A passive library was constructed through an optimization process and comparison of the measured S-parameters with the S-parameters calculated using the momentum simulation. A modeling flow for extracting the passive model elements is shown in Fig. 2. In the CPW library, we considered various discontinuities of the CPWs, such as curves, tees, and crosses, with different impedances of 35, 50, and 70 ohm. Moreover, 800-Å Ti thin-film resistors and 900-Å  $\text{Si}_3\text{N}_4$  metal-insulator-metal (MIM) capacitors were fabricated, and their parameters were extracted to complete the passive device library. The fabricated thin-film resistor and the MIM capacitor showed a resistivity range of 30.2~31.9 ohm/□, and a capacitance range of 0.485~0.538 fF/um<sup>2</sup>, respectively.

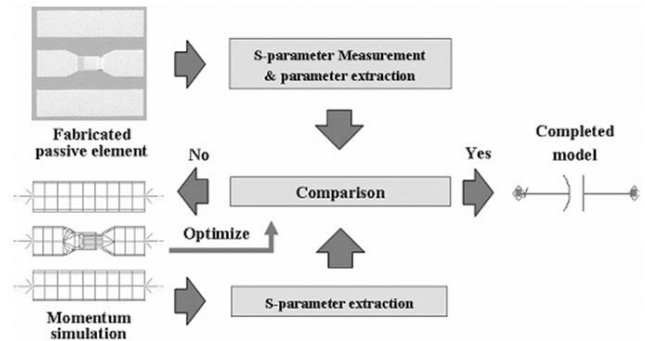

Fig. 2. Modeling flow for the passive elements.

### III. DESIGN AND FABRICATION OF THE V-BAND MMIC MODULES

#### 1. CPW-to-Waveguide Transition

In order to mount the fabricated MMIC chip sets into the V-band wireless transceiver, we fabricated CPW-to-waveguide fin-line transition modules of WR-15 type [7-8].

Transmission lines were fabricated using the RT Duroid 5880 substrates. Figure 3 shows the CPW-to-waveguide transition and housing. From the measurements, an insertion loss of -1.34 dB and a return loss of -27.13 dB were obtained at 58 GHz. After de-embedding, an average insertion loss of -0.56 dB for the

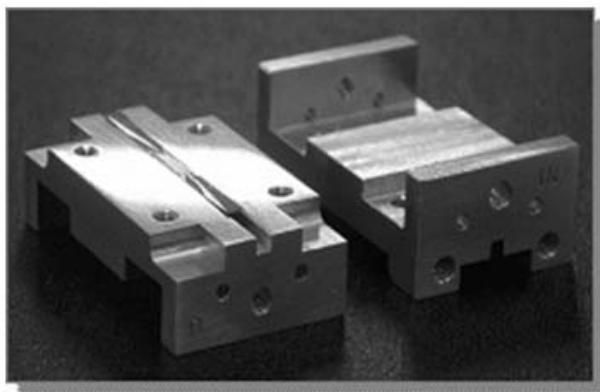
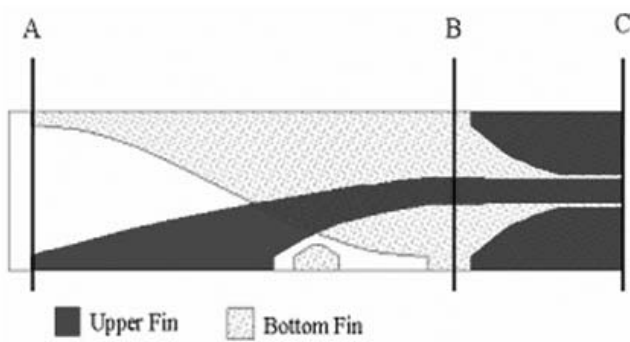

Fig. 3. The CPW-to-waveguide transition and housing : (a) Layout of CPW-to-waveguide transition, and (b) transition housing.

transition was obtained in a frequency range from 50 to 70 GHz. As shown in Fig. 4, the measurements showed a desirable broadband characteristic of the fabricated transition. According to Fig. 4, the measured data of the transition show good agreements with the simulation results.

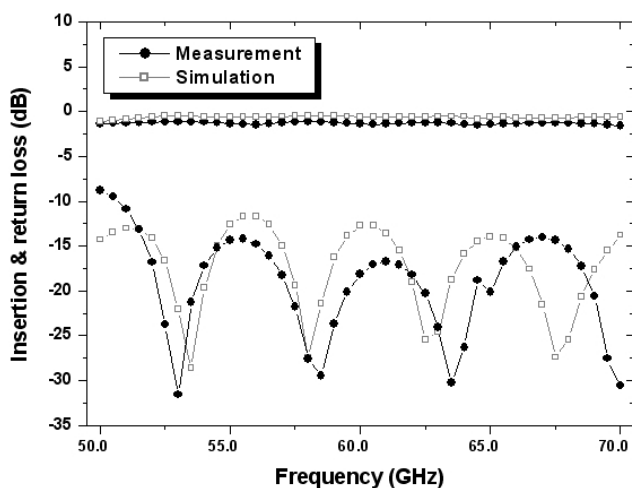
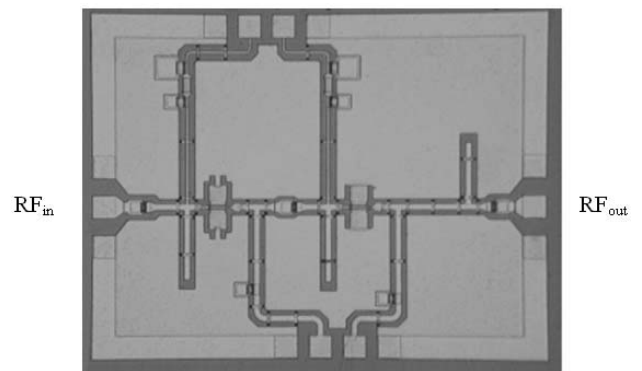

Fig. 4. Measured insertion and return losses of the fabricated CPW-to-waveguide transition.

## 2. Low Noise Amplifier(LNA) Module

In Fig. 5, photographs of the fabricated MMIC LNA chip and the packaged module are shown. In the circuit construction of the 2-stage LNAs, gate bias lines were designed to have short stubs of a quarter-wavelength ( $\lambda/4$ ) with the thin film resistors added to improve the circuit stability. The series feedback was also used to enhance the noise characteristics with a broadband matching. The circuit design was then verified on the total patterns using the full-wave momentum simulation. These V-band LNAs were fabricated by using our standard PHEMT-based MMIC process [9-10].



(a)



(b)

Fig. 5. Photographs of (a) the fabricated MMIC LNA chip (2.1x1.5 mm<sup>2</sup>) and (b) the packaged LNA module.

Good  $S_{21}$  gains of the fabricated LNA chip and the module were 13.1 dB and 8.3 dB at 58 GHz, respectively. The measured S-parameters and noise figures are illustrated in Figs. 6 and 7. As shown in the plots, the LNA chip and the module showed noise figures of 3.6 and 5.6 dB, respectively, at 58 GHz.

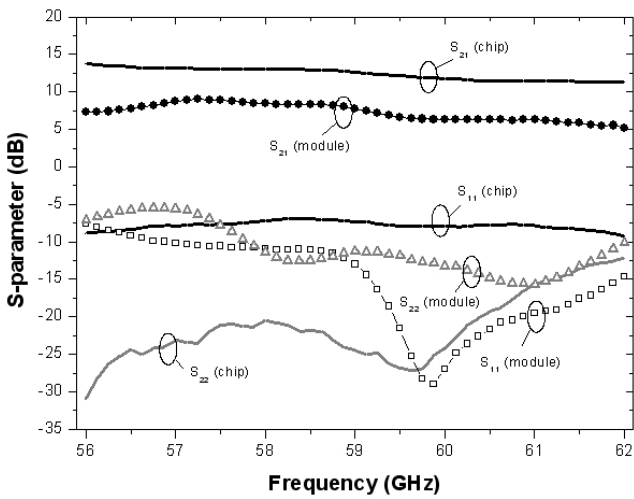

Fig. 6. Measured S-parameters of the V-band LNA chip and the module.

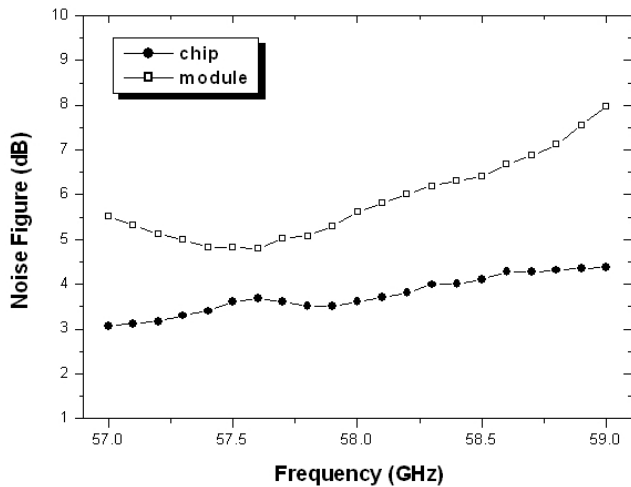

Fig. 7. Measured noise figures of the V-band LNA chip and the module.

### 3. Medium Power Amplifier(MPA) Module

We designed a MMIC amplifier optimized for the class-A operation to obtain good linearity characteristics, and a conjugate matching method was used for achieving a good power gain. The first stage of the MPA was designed to improve output power gain. The output from the second stage of the MPA was designed to have a power-matching point of the HEMT for high output power characteristics. Photographs of the fabricated MPA chip and packaged module are presented in Fig. 8. The total chip area of the fabricated MPA is 3.2x1.4 mm<sup>2</sup>.

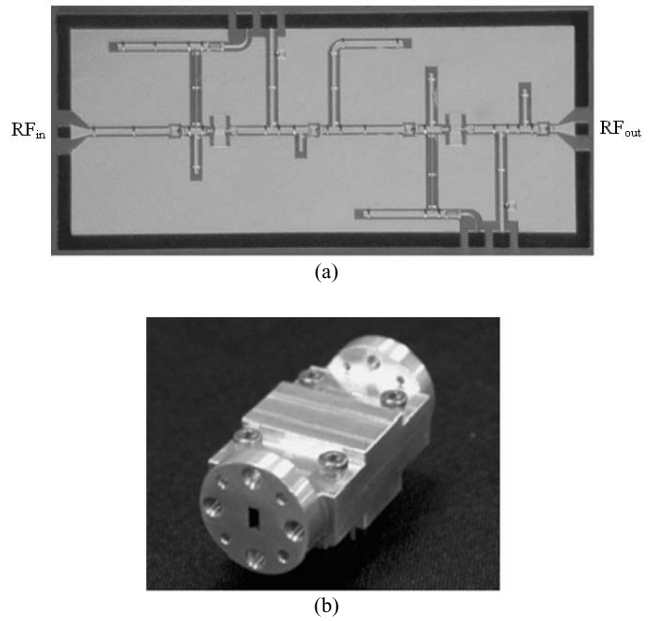

Fig. 8. Photographs of (a) the fabricated MMIC MPA chip (3.2x1.4 mm<sup>2</sup>) and (b) the packaged MPA module.

Figure 9 shows the measured S-parameters in a frequency range from 56 to 62 GHz. The MPA chip showed a high S<sub>21</sub> gain of 11.04 dB at 58 GHz, and this was due to high performances of the fabricated PHEMTs and design optimization. The MPA module showed a S<sub>21</sub> gain of 6.9 dB at 58 GHz after packaging. The power measurements are shown in Fig. 10. The output powers of the MPA chip and the module were measured by sweeping the input powers from -15 to 5 dBm. As shown in Fig. 10, P<sub>1dB</sub> of the MPA chip and the module were 6.9 and 5.4 dBm, respectively, at 58 GHz.

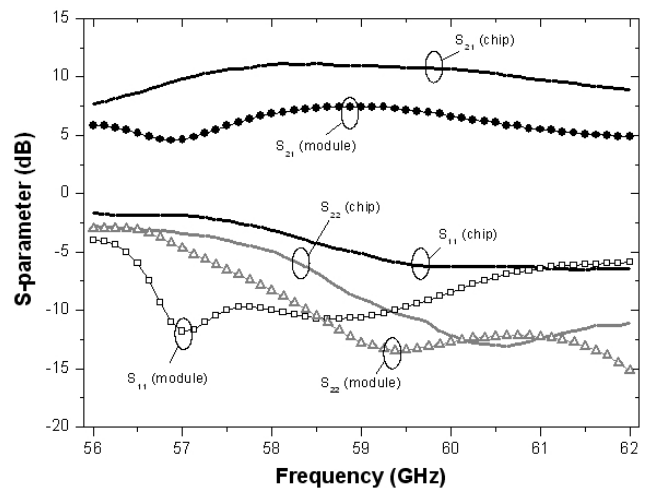

Fig. 9. Measured S-parameters of the V-band MMIC MPA chip and the module.

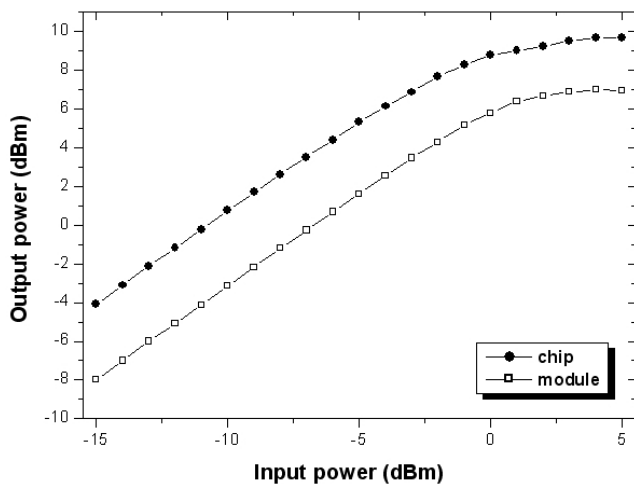

Fig. 10. Measured output powers of the V-band MMIC MPA chip and the module.

#### 4. Up-mixer Module

A single-balanced structure was used for the up-mixer to have a high LO-RF isolation. The electromagnetic field transition of the waveguide-to-microstrip was designed to have broadband and low loss by using an antipodal fin-line structure in a LO port. To improve the LO-RF isolation, a

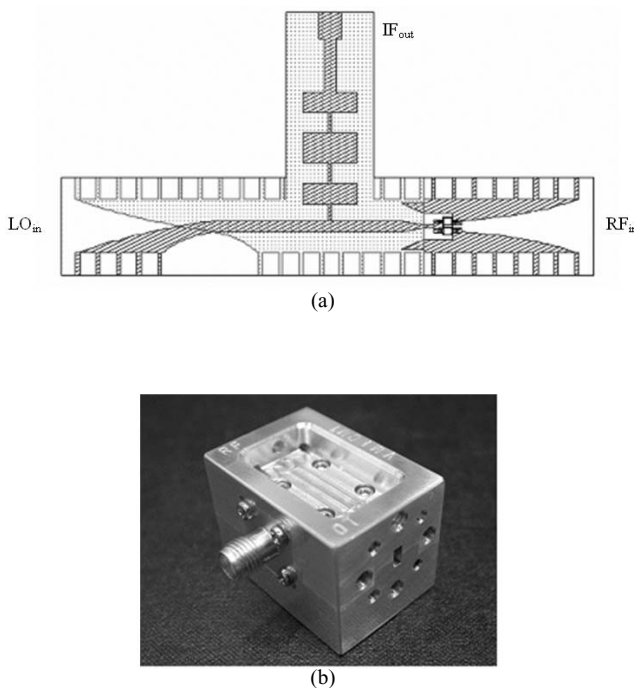

Fig. 11. (a) Layout of the designed V-band up-mixer and (b) the photograph of the up-mixer module.

CPW-based 180° balun was used for the RF port [11-12]. The designed circuit layout of the single-balanced mixer and the up-mixer module are shown in Fig. 11. Figure 12 shows the conversion loss measured at various LO input power and LO-RF isolation measured in a frequency range from 57.5 to 58.5 GHz. As shown in the plots, a conversion loss of 14.3 dB was measured at LO power of 15 dBm, and a LO-RF isolation of 24.5 dB was obtained at a LO frequency of 58 GHz.

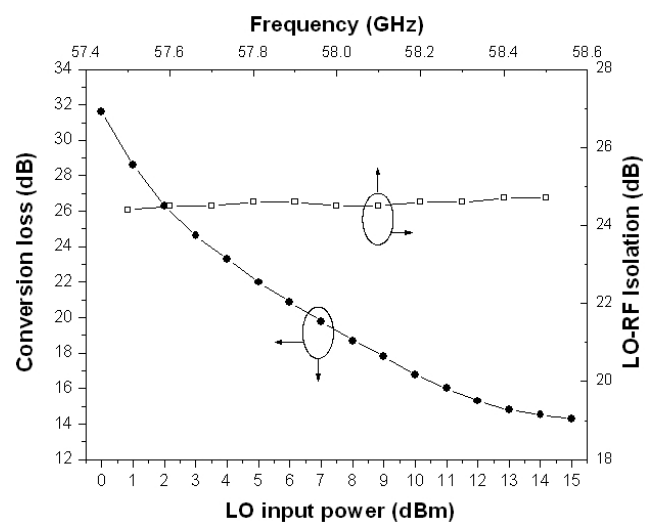

Fig. 12. Conversion loss versus LO input power, and LO-RF isolation versus frequency.

#### 5. Down-mixer Module

Down-converters adopted a square-law detector structure using LO leakages of the transmitter. The LO and RF were inputted in a gate port, while the IF output was located in the drain port. RF, LO and IF frequencies were set to 57.86~58.14 GHz, 58 GHz and 140 MHz, respectively. Figure 13 shows the fabricated down-mixer chip and the packaged module. The total chip area is 1.3x1.2 mm<sup>2</sup>. From the measurement, the conversion losses of down-mixer chip and module were 15.2 dB and 19.7 dB at a LO power of 0 dBm, respectively. Figure 13 illustrates the conversion losses versus the LO input power of the down-mixer chip and the module.

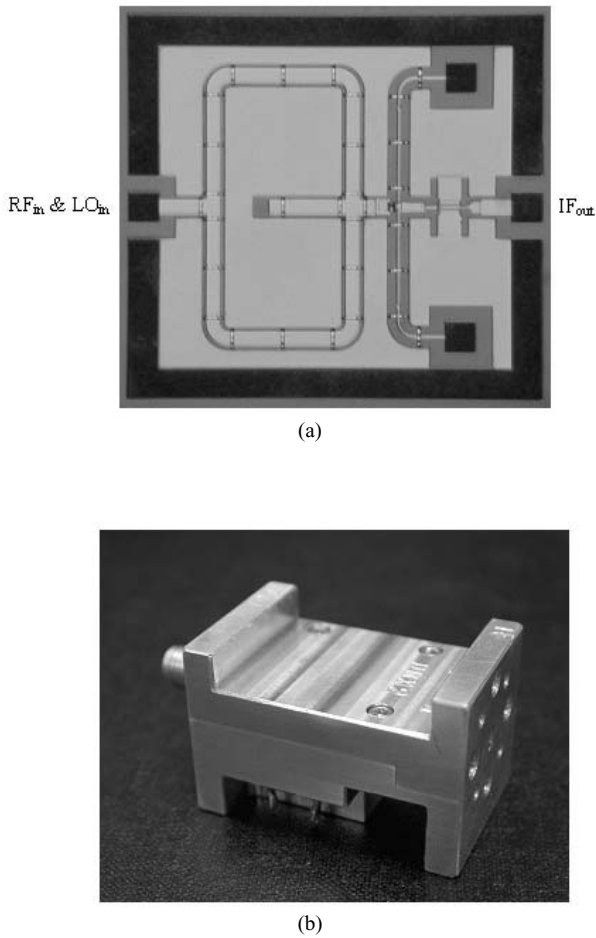

Fig. 13. Photographs of (a) the fabricated down-mixer chip (1.3x1.2 mm<sup>2</sup>) and (b) the packaged down-mixer module.

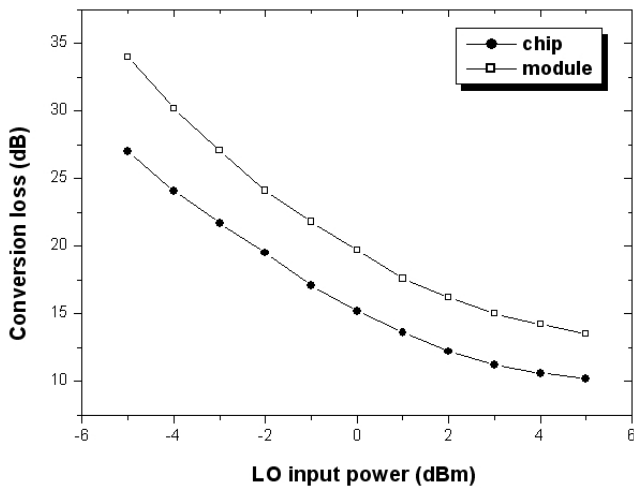

Fig. 14. Conversion losses versus LO input power of the V-band down-mixer chip and the module.

#### IV. FABRICATION AND PERFORMANCE OF V-BAND WIRELESS TRANSCEIVER

A V-band wireless transceiver system was developed by using a DSB self-heterodyne structure with no filter and LO in the receiver block. For the high productivity and low cost solution, MMIC modules for the transceiver system were also used. The description and block diagram of the V-band wireless transceiver system are shown in Table 1 and Fig. 15, respectively. Besides MMIC modules, a switch for the TDD (time-division duplexing), a horn antenna, and a circulator were used for constructing the self-heterodyne transceiver system .

To evaluate performance of the V-band wireless transceiver, we measured the amplification block, by measuring the conversion gains and output powers of the transmitter and the receiver parts. Figure 16 depicts measured S-parameters of the transmitter amplification block, which is composed of a LNA module as a drive-amplifier and a MPA module. The measured S<sub>21</sub> and S<sub>11</sub> of the transmitter amplification block were 14.5 and -10.3 dB, respectively, while a S<sub>22</sub> of -7.4 dB were obtained at RF frequency of 58 GHz.

Table 1. Description of the V-band wireless transceiver.

Item	Specification
Communication	TDD/TDMA
Signal transmission scheme	DSB(Double Side Band) Self-heterodyne
Input/output IF frequency	140 MHz
RF frequency	58.14 and 57.86 GHz
LO frequency	58 GHz
Data rate per channel	25 Mbps
Switching speed	< 10 μsec

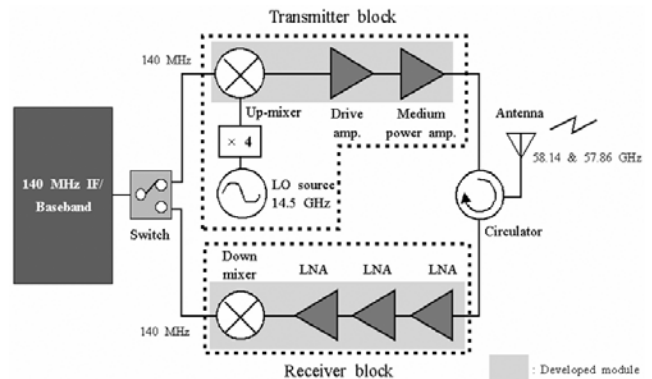

Fig. 15. Block diagram of the V-band wireless transceiver.

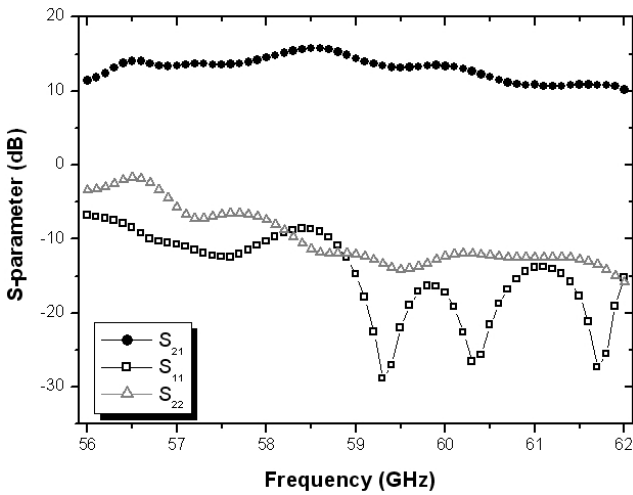

Fig. 16. Measured S-parameters of the transmitter amplification block.

Furthermore, we obtained a conversion gain of 0.21 dB and an output power (1 dB compression point) of 5.2 dBm from the transmitter. Figure 17 shows an output spectrum of the transmitter at an IF input frequency of 140 MHz and an IF input power of 0 dBm. Shown in Fig. 18 is the output power and the conversion gain versus the IF input power of the V-band transmitter at an IF input frequency of 140 MHz and a LO frequency of 58 GHz.

Figure 19 illustrates measured S-parameters of the receiver amplification block, which is composed of three LNA modules. The measured  $S_{21}$  and  $S_{11}$  of the receiver amplification block were 22.6 and -12.1 dB, respectively, while a  $S_{22}$  of -13.9 dB were obtained at RF frequency of 58 GHz.

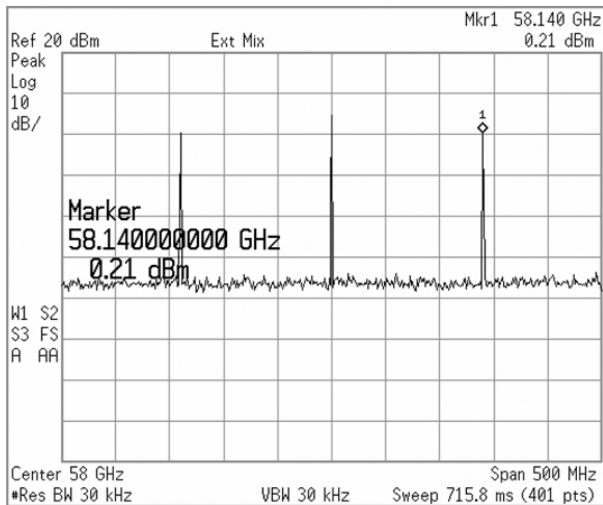

Fig. 17. Output spectrum of the V-band transmitter (IF input frequency = 140 MHz, IF input power = 0 dBm).

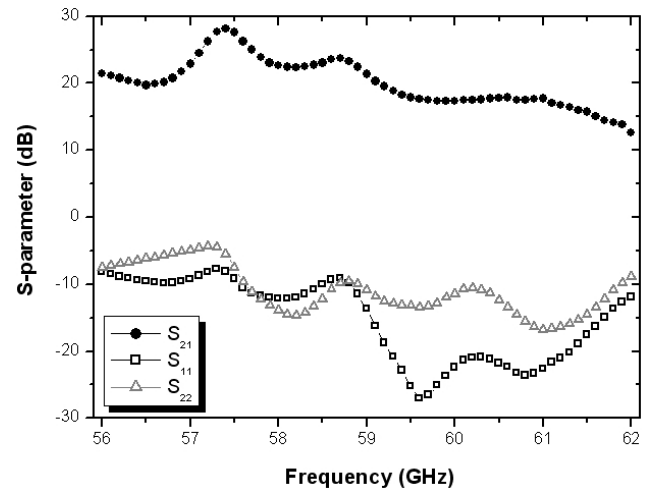

Fig. 19. Measured S-parameters of the receiver amplification block.

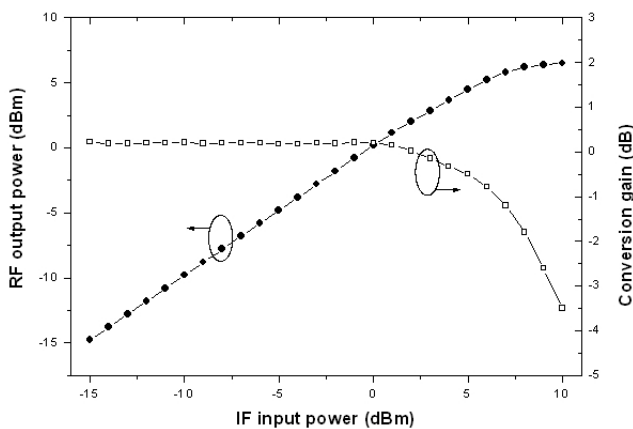

Fig. 18. RF output power and the conversion gain versus the IF input power of the V-band transmitter (IF input frequency = 140 MHz, LO frequency = 58 GHz).

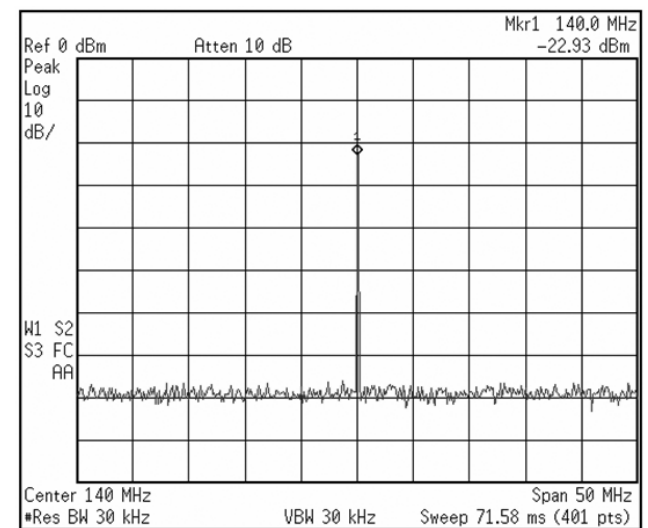

Fig. 20. Output spectrum of the V-band receiver (RF input frequency = 58.14 and 57.86 GHz, RF input power = -25 dBm, LO frequency = 58 GHz, LO input power = -22 dBm).

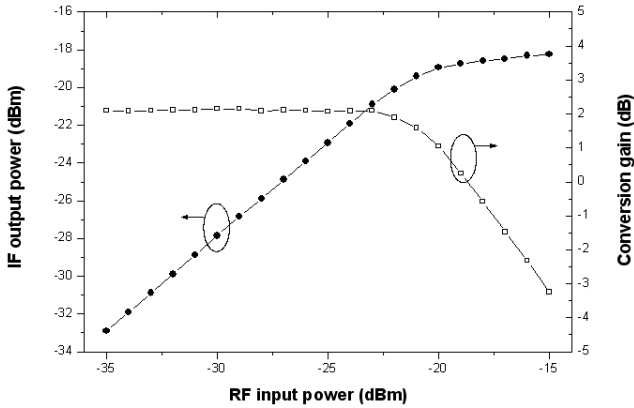

Fig. 21. IF output power and the conversion gain versus the RF input power of the V-band receiver (RF input frequency = 58.14 and 57.89 GHz, LO frequency = 58 GHz, LO input power = -22 dBm).

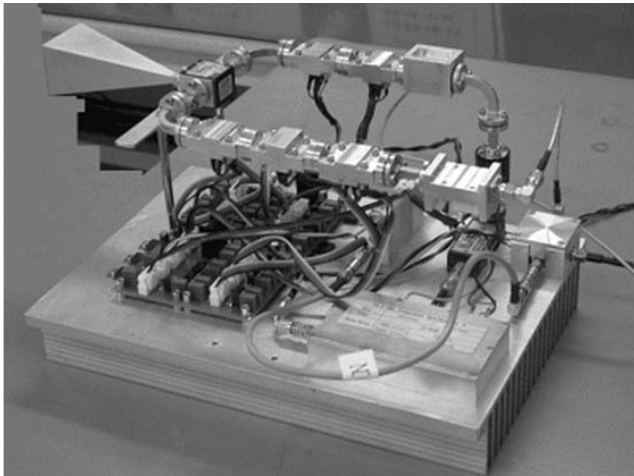

Fig. 22. The developed V-band wireless transceiver system.

From the receiver part, we obtained a conversion gain of 2.1 dB and an output power (1 dB compression point) of -18.6 dBm. Shown in Fig. 20 is the output spectrum of the receiver at a RF input power of -25 dBm and a LO input power of -22 dBm. Figure 21 shows the measured

output powers and the conversion gains versus the RF input power of the V-band receiver at a LO input power of -22 dBm.

Performance of the developed transceiver system is summarized in Table 2. From the transmitter, an output power of 5.2 dBm and a conversion gain of 0.2 dB were obtained, while a conversion gain of 2.1 dB was measured from the receiver. Figure 22 shows the developed V-band wireless transceiver. From the link tests of the transceiver, the V-band wireless transceiver system demonstrated a successful data transfer, showing an BER smaller than  $10^{-6}$ , within a distance of 5 meters.

### V. CONCLUSIONS

We report on a low-cost V-band wireless transceiver with no use of any LO in the receiver block. The V-band MMIC modules were developed to demonstrate the V-band wireless transceiver using coplanar waveguide (CPW) and GaAs PHEMT technologies. The MMIC chips such as the MMIC LNA, MPA, and the down-mixer were installed in the transceiver system. To mount the MMIC chips onto the module for the transceiver systems, CPW-to-waveguide transition modules of WR-15 type were fabricated. From the measurement of the V-band wireless transceiver, a conversion gain of 0.2 dB and a  $P_{1dB}$  of 5.2 dBm were obtained from the transmitter block. The receiver block showed a conversion gain of 2.1 dB and a  $P_{1dB}$  of -18.6 dBm. From the link tests, the wireless transceiver system showed successful data transfer (BER <  $10^{-6}$ ) within a distance of 5 meters.

Table 1. Performance of the V-band wireless transceiver system.

Item	Transmitter	Receiver
Input frequency	140 MHz	RF: 58.14 & 57.86 GHz LO: 58 GHz (From antenna)
Output frequency	RF: 58.14 & 57.86 GHz LO: 58 GHz (To antenna)	140 MHz
Amplification block gain	14.5 dB (at 58 GHz)	22.6 dB (at 58 GHz)
Mixer conversion loss	14.3 dB (at LO = 15 dBm)	19.7 dB (at LO = 0 dBm)
Conversion gain	0.2 dB (at LO = 15 dBm)	2.1 dB (at LO = -22 dBm)
Output power ( $P_{1dB}$ )	5.2 dBm	-18.9 dBm

### ACKNOWLEDGMENTS

This work was supported by Korea Science and Education Foundation (KOSEF) under Engineering Research Center (ERC) program through the Millimeter-Innovation Technology (MINT) research center at Dongguk University in Seoul, Korea. Authors would like to thank Dr. Ogawa at National Institute of Information and Communications Technology (NiCT) for collaboration effort.

## REFERENCES

- [1] Y. Shoji, K. Hamaguchi, and H. Ogawa, "A Low-Cost and Stable Millimeter-Wave Transmission System Using a Transmission-Filter-Less Double-Side-Band Millimeter-Wave Self-Heterodyne Transmission Technique," *IEICE TRANS. COMMUN.*, pp. 1884-1892, June 2003.
- [2] S. C. Kim, B. O. Lim, H. S. Kim, S. D. Lee, B. H. Lee, W. S. Sul, D. H. Shin, and J. K. Rhee, "Sub 0.1  $\mu\text{m}$  asymmetric  $\Gamma$ -gate PHEMT process using electron beam lithography," in *proceedings of 28th International Symposium Compound Semiconductors*, pp. 95-100, 2001
- [3] H. Statz, P. Newman, I. Smith, R. Pucel, H. Haus. "GaAs FET device and circuit simulation in SPICE," *IEEE Trans. Elec. Devices*, vol. ED-34, pp. 160-169, Feb. 1987.
- [4] J. M. Golio, M. Miller, G. Maracus, and D. Johnson, "Frequency dependent electrical characteristics of GaAs MESFETs," *IEEE Trans. Elec. Devices*, vol. ED-37, pp. 1217~1227, May 1990.
- [5] Dan An, Sung Chan Kim, Woo Suk Sul, Hyo Jong Han, Hyung Moo Park, and Jin Koo Rhee, "High Conversion Gain Millimeter-wave  $\times 4$  Subharmonic Mixer with Cascode 4-th Harmonic Generator," *Microwave Optical Tech. Lett.*, vol. 41, no. 6, pp. 490~493, June 2004.
- [6] Won-Young Uhm, Bok-Hyung Lee, Sung-Chan Kim, Mun-Kyo Lee, Woo-Suk Sul, Sang-Yong Yi, Yong-Hoh Kim, Jin-Koo Rhee, "High Conversion Gain Q-band Active Sub-harmonic Mixer Using GaAs PHEMT," *Journal of Semiconductor Technology and Science*, vol. 3, no. 2, pp. 89~95, June 2003.
- [7] D.H. Ko, J.Y. Moon, D. An, M.K. Lee, S.J. Lee, J.M. Jin, Y.S. Chae, S.W. Yun, S.D. Kim, H.M. Park, and J.K. Rhee, "V-band Waveguide-to-Coplanar Waveguide Transition for 60 GHz Wireless LAN application," *34<sup>th</sup> European Microwave Conference*, pp. 641-644, Oct. 2004.
- [8] Jimmy G. M. Yip, Adam K. Jastrzebski, Richard J. Collier, and Daiqing Li, "The Design of Waveguide-to-Fineline Taper Transitions at Millimeter Wave Frequencies," *Microwaves, Radar and Wireless Communications 2002*, vol.1, pp. 282-285, May 2002.
- [9] I.H. Lee, S.D. Lee, and J.K. Rhee, "Studies on Air-Bridge Processes for mm-wave MMIC's Applications," *Journal of the Korean Physical Society*, vol. 35, no. 12, pp. S1043-S1046, Dec. 1999.
- [10] Tae-Sin Kang, Seong-Dae Lee, Bok Hyung Lee, Sam-Dong Kim, Hyun Chang Park, Hyung Moo Park, and Jin Koo Rhee, "Design and Fabrication of a Low Noise Amplifier for V-band," *J. Korean Phys. Soc.*, vol. 41, no. 4, pp. 533 ~538, Oct. 2002.
- [11] Jimmy G.M. Yip, Adam K. Jastrzebski, Richard J. Collier and Daiqing Li, "The design of waveguide-to-fineline taper transitions at millimetre wave frequencies," *Microwaves, Radar and Wireless Communications, 2002. MIKON-2002. 14<sup>th</sup> International Conference*, vol 1, pp. 282-285, May 2002.
- [12] Yi-Chi Shih, Thuy-Nhung Ton, and Long Q. Bui, "Waveguide-to-microstrip transitions for millimeter-wave applicatoions," in *IEEE MTT-S Dig.*, vol 1, pp. 473-475, May 1988.



**Dan An** He received the B. E. degrees in electronics engineering from Dongguk University, Seoul, Korea, in 1998, and M. E. degrees in electrical engineering Dongguk University, Seoul, Korea, in 2000. He is currently Ph. D. course of Dongguk University,

Seoul, Korea.

Since 1999, he has studied in Millimeter-wave INnovation Technology Research Center (MINT), Seoul, Korea. His major field of study is the MMIC design and the microwave device modeling.



**Mun-Kyo Lee** He got a B.E. degree in electronic engineering from Paichai University, Korea, in 1999. Also, he received a M.E. degree in electronics from Dongguk University at Seoul, Korea, in 2001.

He has been working toward the Ph.D. degree. His research interests include MMIC and RF system design.



**Sang-Jin Lee** He received the B. S. degrees in Department of information and communication engineering from Joongbu University in 2003, and M. E. degrees in electrical engineering Dongguk University, Seoul, Korea, in 2005. He is currently Ph. D. course of

Dongguk University, Seoul, Korea. Since 2005, he has studied in Millimeter-wave INnovation Technology

Research Center (MINT), Seoul, Korea. His major field of study is the MMIC design and the microwave device modeling and V-band MMIC and System.

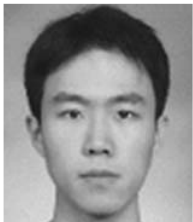

**Du-Hyun Ko** He received the B. S. degrees in degrees in electrical engineering Dongguk University in 2003, and M. E. degrees in electrical engineering Dongguk University, Seoul, Korea, in 2005.

His major field of study is the MMIC design, transition design and V-band MMIC and System.



**Jin-Man Jin** He received the B. S. Department of electronics engineering from National Hankyong university in 2002, and M. E. degrees in electrical engineering Dongguk University, Seoul, Korea, in 2005.

His research interests V-band MMIC and System.



**Sung-Chan Kim** He received the B.E and M.E. degrees from the University of Dongguk at Seoul, Korea, in 1999 and 2001, respectively, and is currently working toward the Ph. D degree in electronic engineering.

At the University of Dongguk, he was a number of the Millimeter-wave Innovation technology research center (MINT). His research interests include GaAs-based RF MEMS devices, compound semiconductor devices, and MMIC technology for millimeter-wave applications.



**Sam-Dong Kim** He received the B.E. degree from the Seoul National University, Korea, in 1983, the M.E. degree from Seoul National University, Korea, in 1985, and the Ph. D. in department of material science and engineering from Stanford University,

USA, in 1992. He worked for Hyundai electronics Co. Ltd., Korea, as a senior research staff. His research interests include millimeter-wave devices and noble semiconductor device processes.

Prof. Kim is currently a professor in Department of

electronic engineering, Dongguk University, Korea.



**Hyun-Chang Park** He received the B.E. degree in electronic engineering from Seoul National University, Seoul, Korea, in 1986, and the M.E. and the Ph.D. degrees in electrical engineering from Cornell University, Ithaca, NY, in 1989 and 1993, respectively.

He is currently a professor in the Department of Electronic Engineering, Dongguk University, Seoul, Korea. His research interest includes high-frequency semiconductor devices, MMIC, and MEMS.



**Hyung-Moo Park** He received the B.E. degree in electronic engineering from Seoul National University, Seoul, Korea, in 1978, and the M.E. and the Ph.D. degrees in electrical engineering from Korea Advanced Institute of Science and Technology (KAIST),

Seoul, in 1980 and 1984, respectively. After graduate, he was working at Semiconductor Division of ETRI, Korean IT research institute until 1999. He is currently a professor in the Department of Electronic Engineering, Dongguk University, Seoul, Korea. His research interest includes millimeter wave system and circuit design.



**Jin-Koo Rhee** He received the B.E. degree from the Hankuk Aviation University, Korea, in 1969, the M.E. degree from Seoul National University, Korea, in 1975, and the Ph. D in department of electronic engineering from Oregon State University, USA, in

1982.

He worked for Cray Research and Microwave Semiconductor Corporation, USA, as a research scientist, and visited Dept. of EECS, University of Michigan as a visiting research scientist. His research interests include millimeter-wave devices, circuits, and systems.

Prof. Rhee is currently a professor in Department of electronic engineering, Dongguk university, a president of IEEK, and a director of Millimeter-wave INnovation Technology research center (MINT).